

Motivation in Innovation Projects

Dr. Sebastian Kunert

08.05.2014

Auszug aus dem Konferenzbeitrag „Time, Staff and Motivation in Innovation Projects - New Empirical Insights“ präsentiert auf der Jahreskonferenz Innovation for Sustainable Economy & Society vom 08. - 11.06.2014 in Dublin | www.conference.ispim.org

In the innovation process literature stage gate models on the one hand and context factors on the other are still dominant. Very little is known about special issues regarding innovation project characteristics. Case studies suggest that the way innovation projects are staffed and managed is highly related to success. The present study investigates the motivation in innovation projects empirically. We analyzed data from 41 interviews. The results suggest that variance in motivation during the project is negatively associated with success. That implies practical suggestions for managers for how to staff and lead in innovation projects.

Research in innovation process characteristics

[...] Van de Ven and colleagues conducted a rare longitudinal study in 18 companies between 1982 and 2000 in order to investigate success factors for innovation processes and to identify an ideal procedure in idea management. Their conclusion still summarizes the current state in the field: „No overarching process theory of innovation has yet emerged from the research program, nor are prospects bright in the near future.“ (p. 4; see also Hobday, 2005; Mahdi, 2002). Pavitt (2006) concluded his investigations with the statement: „There is no widely accepted theory of

firm-level process of innovation.“ (p. 87). Nevertheless, organizations want to structure and staff their projects effectively to raise the probability of success and save resources at the same time. Given that need, several critical variables are well known (for an overview see Belassi & Tukel, 1996; Brown, Schmied & Tarondeau, 2002). Overall, top management support, clear goals, resources, communication, and scheduling seem to be the most crucial elements. The importance of these factors differ depending on the stakeholders (Davis, in print), the definition of success, the industry, the organizational structure, and the size of the project (Belassi & Tukel, 1996). [...]

[...] The importance and development of motivation among team members during an innovation project is also not extensively investigated so far. Research in job satisfaction (Judge, Bono, Thoresen & Patton, 2001) and readiness for change (Armenakis, Harris & Mossholder, 1993) suggest some importance. Case studies report a threatening 'valley of tears' but remain anecdotal (van de Ven, Angle & Poole, 2000). The present study aims to investigate time, staff and motivation related factors in innovation projects empirically. [...]

Methods

[...] We conducted an interview study with 41 participants in 5 different companies. We reconstructed the last innovation project of each interviewee by assessing the single steps of the entire process, their respective activity, the result, the duration and the number of participants. In addition, we asked for a subjective rating of the individual motivation to continue the project at every process step on a Likert scale (-10 to +10). To measure innovation success we also asked the interviewees to rate the likelihood for the project to succeed at every process step on a Likert scale (-10 to +10). After that, we averaged the ratings in order to compute a process sensitive value of project success. The interview sample consisted of 6 senior managers, 14 people from middle management and 21 lower level employees (cf. Markusch, 2011). [...]

Results

[...] On a scale ranging from -10 to +10 the average motivation was slightly positive (Mean = 3.94), variance was quite high (Standard Deviation = 3.54; Minimum = -4.65, Maximum = 3.75). Average motivation is highly correlated with project success, $r = .54^{***}$. In contrast, variance is negatively correlated, $r = -.44^{**}$. To understand the

importance of motivational changes during the project we divided every project in ten equal time parts and calculated the average motivation in each period. Motivation trajectories could be categorised into four characteristic shapes. In 34% of all cases values rise up during the process, meaning all graphs start near to or below the average line and end above (Figure 1).

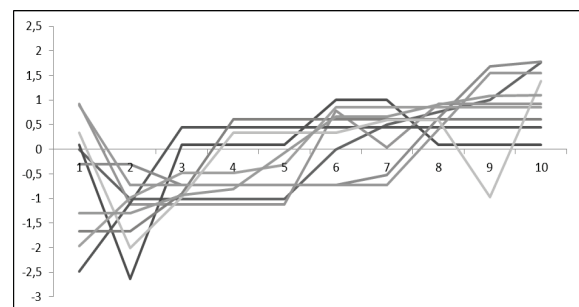

x-coordinate = decimile (tenth parts of individual total project duration)

y-coordinate = z-values of individual motivation scores.

Figure 1 Interview cases with uprising shaped changes in motivation. Graphs start near to or below the average line and end above.

In 24% of the cases the motivation declines, when all graphs start above the average line and end below (Figure 2).

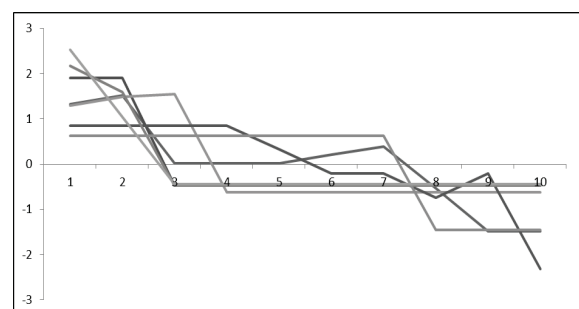

x-coordinate = decimile (tenth parts of individual total project duration)

y-coordinate = z-values of individual motivation scores.

Figure 2 Interview cases with decreasing shaped changes in motivation. Graphs start above the average line and end below.

Another 24% show a U-shape: the graphs start near to or above the average line, drop below at a certain point in time and end ap-

proximately at the starting point (Figure 3). Interestingly, maximum frustration is not always at the same time but occurs anywhere from the third to the ninth decentile.

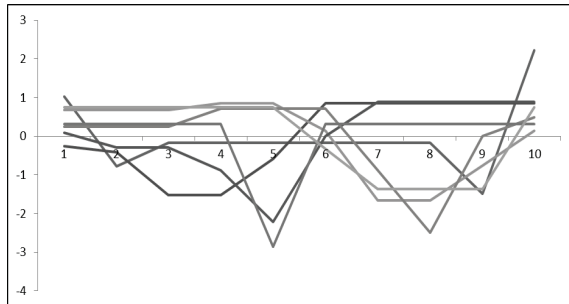

x-coordinate = decentile (tenth parts of individual total project duration)

y-coordinate = z-values of individual motivation scores.

Figure 3 Interview cases with U-shaped changes in motivation. Graphs start near to or above the average line, drop below and end approximately at the starting point.

The remaining 18% show a wave-like graph that crosses the average line at least two times (Figure 4).

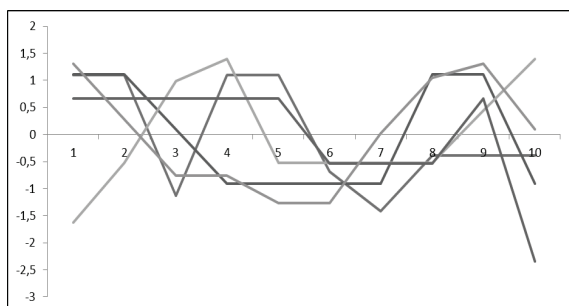

x-coordinate = decentile (tenth parts of individual total project duration)

y-coordinate = z-values of individual motivation scores.

Figure 4 Interview cases with wave-like changes in motivation. Graphs cross the average line at least two times.

A One-Way ANOVA of the 4 different shape types showed no significant influence on project success, $F = 0.39$. In summary, a 'valley of tears' in motivation as argued by van de Ven, Angle & Poole (2000) was not dominant. In fact, in three of four interviews other types of shapes occurred. However, the progress of trajectories is not so important but the aver-

age level (should be high) and changes over time (should be small). [...]

Conclusion

[...] Managers should be aware of motivation during the process. Unsurprisingly, high values in motivation support success. But even more importantly, fluctuations should be avoided, because too much swaying decreases success probability. Investigating climate, satisfaction and compliance by surveys, interviews or by a person of trust from time to time helps managers to monitor this human factor. Therefore, a mixture of task oriented and socially oriented management activities aimed at meeting time requirements and keeping team motivation high is the best way to lead an innovation project to success. More specifically, Hooijberg (1996) provides a "circumplex" model of innovation process for leadership, in which eight somewhat contradictory roles are systematically arranged around the perimeter of a circle. Following the authors, managers must show some behavioural complexity, which basically means that they should adjust their leadership style to the leadership requirements flexibly. Even more concretely, De Jong & Den Hartog (2007) describe thirteen explicit behaviours designed to support members of innovation projects. [...]

References

- Armenakis, A. A., Harris, S. G. & Mossholder, K. W. (1993). Creating readiness for organizational change. *Human Relations*, 46, pp. 681-703.
- Brown, K., Schmied, H. & Tarondeau, J.-C. (2002). Success factors in R&D: A meta-analysis of the empirical literature and derived implications for design management. *Academic Review*, 2 (1), pp. 72-87.
- Belassi, W. & Tukel, O. I. (1996). A new

framework for determining critical success/failure factors in projects. *International Journal of Project Management*, 14 (3), pp. 141-151.

Davis, K. (in print). Different stakeholder groups and their perceptions of project success. *International Journal of Project Management*.

de Jong, J. P. J. & Den Hartog, D. N. (2007). How leaders influence employees' innovative behaviour. *European Journal of Innovation Management*, 10 (1), pp. 41-64.

Hobday, M. (2005). Firm-level innovation models: perspectives on research in developed and developing countries. *Technology Analysis and Strategic Management*, 17, pp. 121-46.

Hooijberg, R. (1996). A multidirectional approach toward leadership: an extension of the concept of behavioral complexity. *Human Relations*, 49 (7), pp. 917-946.

Judge, T.A., Bono, J.E., Thoresen, C.J. & Patton, G.K. (2001). The Job Satisfaction-Job

Performance Relationship: A Qualitative and Quantitative Review. *Psychological Bulletin*, 127, pp. 376-407.

Mahdi, S. (2002). Search Strategy on Product Innovation Process: Theory and Evidence from the Evolution of Agrochemical Lead Discovery Process. *Abstracts of Papers of the American Chemical Society 224*, Part 1.

Markusch, D. (2011). Bestandteile guter Innovationsprozesse und subjektive Erfolgsfaktoren speziell für klein- und mittelständische Unternehmen. Berlin: HU Berlin. [On-line] <http://edoc.hu-berlin.de/master/markusch-dorothea-2011-02-02/PDF/markusch.pdf>.

Pavitt, K. (2006). Innovation Processes. In: J. Fagerberg, D. Mowery & R. Nelson (Hrsg.). *The Oxford Handbook of Innovation*. Oxford: Oxford University Press. pp. 86-114.

Van de Ven, A. H., Angle, H. & Poole, M. S. (2000). *Research on the management of innovation: The Minnesota Studies*. New York: Oxford University Press.

Über den Autoren



Dr. Sebastian Kunert, Diplom-Psychologe, Berater, Trainer und Dozent. Von 2009 bis 2013 war er Mitglied im Verbundprojekt GI:VE, das sich fördernden und hemmenden Faktoren der Kultur und der Prozessgestaltung auf die Innovationskraft von Unternehmen widmete. Weitere Ergebnisse des Projekts finden sich in der Publikation *Scholl et al. (2014). Mut zu Innovationen. Springer*.

artop GmbH
Institut an der Humboldt-Universität zu Berlin
Christburger Str. 4
10405 Berlin

Telefon.: 030 44 01 29 9-0
Fax: 030 44 01 29 9-21

kunert@artop.de
www.artop.de